

# Installation Package C-box

## GB Instructions for installation, operation and maintenance



### General

The C-box consists of the unit heater, wall brackets, automatic temperature control unit ATC as well as a valve with on/off actuator. The unit heater control system regulates the speed of a single phase fan across three speeds and the fluid valve on/off based on set-point settings and the measured temperature on the corresponding temperature sensor.

### Unit heater

See the separate instructions Unit heater LVD/ATD (A,G)

### Control unit ATC with actuator

The fan speed can be set manually across three speeds, in auto mode or switched off completely. When the fan motor speed is set manually, the fluid valve is automatically switched between its open and closed positions. The LED display indicates in its normal position the fan speeds 0, 1, 2, 3.

The control setting and current set point can be regulated by a wall mounted or infrared remote control. The control system can also be regulated by a main control system via a 0-10V control signal. When a freeze protection sensor is connected it can also operate a mixed air damper.

Switching between indication modes and modifying parameters is performed by pressing the buttons on the front panel, see the chapter List of parameters.

# Installation Package C-box

## Control, fan motor and valve

In auto mode, with a heating requirement, the speed of the fan motor is controlled across three speeds and the fluid valve is open. When the heating requirement is reached the fan stops and the fluid valve closes. When the fan speed is controlled manually the heating is regulated with the fluid valve. The fluid valve is either open or closed without any intermediate positions and is powered by a 230 VAC supply voltage.

Set-point settings for the room temperature and the freeze protection temperature are set on the list of parameters. The room temperature has a separate set point for daytime and night time settings, the active setting is controlled by a low level input for a timer. If the input is short circuited between terminals Z1 and m3 it is the set point value for the night time temperature that applies, otherwise it is the set point value for the daytime temperature that applies. When the remote control is used, the current set point value is changed, that is to say, during the day the remote control changes the set point value for the daytime temperature and during night it changes the set point value for the night time temperature. When controlling with a main control system using a 0-10V control signal this function must be activated in the list of parameters, see chapter List of parameters. The control signal is then used to regulate both the fan speed and the position of the fluid valve, see the chapter Control signal range. When this mode is activated the set point settings for daytime temperature, night time temperature or the measured temperature do not have any significance. However, the freeze protection temperature works as usual to ensure the operation of the system.

## Mixing section (ATD)

When a mixing section is used a freeze protection sensor should be connected and activated in the list of parameters. Approximately two minutes after the daytime setting comes into force a mixing air damper opens according to the corresponding setting in the list of parameters. The mixing air damper closes immediately the night time setting comes into force.

The fluid valve is opened to prevent damage due to freezing while in a deenergized state.

For installation and technical data, see the separate instruction for the mixing section.

## Freeze protection (ATD)

The fluid valve opens fully as soon as the freeze protection temperature falls below the corresponding set point plus 5°C, that is to say, when the set point value is set to +7°C the fluid valve opens fully at +12°C. If the temperature continues to drop to the set point for the freeze protection temperature the alarm trips. Once the alarm trips the fan is switched off and the mixing air damper closes completely to prevent damage due to freezing. A return to normal operations can only take place by disconnecting the power supply to the control unit. In order to prevent the above alarm situation for a too low freeze protection temperature, the sensor input must be short circuited between terminals GT2 and N2 when a freeze protection sensor is not used, otherwise the alarm will trip continuously (supplied design).

## Alarm

An alarm trips when the fan motor draws surprisingly little current, that is to say, when a voltage is placed on the motor output and the circuit to the fan is broken. This is indicated on the LED display with the text "AL 01". An alarm can also trip when the freeze protection sensor reads a temperature that is lower than the corresponding set point. This alarm is indicated on the LED display with the text "AL 02". Over and above these alarm indications, alarms are given on the appropriate relay outputs.

# Installation Package C-box

## List of parameters

The arrow buttons are used to scroll through the parameters. When a parameter can be modified, press on the SET button and then use the arrow buttons to modify the parameter value. Press SET again to exit modifying mode.

Parameter	Description	LED-display	Modifiable	Initial value	Min value	Max value
0	Fan speed indication (0-3)	"FS xx"	No		0	3
1	Actual room temperature value indication	"01 xx"	No		0	40
2	Actual freeze protection temperature value indication	"02 xx"	No		0	40
3	Valve position indication (open/closed or %)	"03 xx"	No		CL 0	oP 99
4	Mixing ratio outdoor air indication (%)	"04 xx"	No		0	99
5	Fan control mode selection (AUT or 0-3)	"05 x"	Yes	4	0	4
6	Speed in min mode selection	"06 x"	Yes	0	0	1
7	Selection of the set point room temperature daytime	"07 xx"	Yes	20	5	35
8	Selection of the set point room temperature night time	"08 xx"	Yes	15	5	35
9	Selection of the set point freeze protection temperature	"09 xx"	Yes	7	5	20
10	Activation of 0-10V control signal in	"10 xx"	Yes	oF	oF	on
11	Activation of the mixing function Requires a freeze protection sensor	"11 xx"	Yes	oF	oF	on
12	Selection of the mixing ratio outdoor air	"12 xx"	Yes	0	0	99
13	Selection of the address for group connection	"13 xx"	Yes	0	0	FF

## Control signal range

A hysteresis function is applied to the control signal, which is why you should place the control signal in the middle of the defined signal range below to obtain the expected result.

- When the control signal lies under 1.8 V the fan is completely switched off.
- When the control signal lies between 2.0-4.0 V the fan starts at speed 1.
- When the control signal lies between 4.0-6.0 V the fan starts at speed 2.
- When the control signal is above 6.0 V the fan starts at speed 3.
- When the control signal is below 2.2 V or the fan is switched off the fluid valve closes.
- When the control signal is above 2.4 V and the fan is activated the fluid valve opens.

## Temperature range

A hysteresis function is applied to the measured temperature.

- When the temperature is 0.1 °C below the set value the fan is completely switched off.
- When the temperature lies 0.6-1.1 °C below the set value the fan starts at speed 1.
- When the temperature lies 1.6-2.0 °C below the set value the fan starts at speed 2.
- When the temperature is 2.5 °C below the set value the fan starts at speed 3.
- When the temperature is 0.3 °C below the set value or the fan is switched off the fluid valve closes.
- When the temperature lies 0.8 °C below the set value and the fan is activated the fluid valve opens.

# Installation Package C-box

## Connection description

### Voltage

The supply voltage, fuse protected max 10 A, is connected to the terminals L1, N and earth.

### Fan

A fan motor of max 2 A is connected to terminals Lm, Nm and earth.

The unit has no connections for the connection of the fan motor's thermal switch, but it is equipped with monitoring of the motor current to the fan motor. This permits the fan motor's thermal switch to be connected in series with its motor current connection to give the equivalent functionality.

### Freeze protection

A freeze protection sensor must be placed on the return water pipe in order for the mixing of outdoor air function to be activated. Connection to the temperature control unit is made between terminals GT2 and M2; the existing strap should be removed.

### Timer

A timer can be connected to utilise the functions for different set points daytime and night time and to automatically close the mixing air damper night time. The timer is connected between terminals Z1 and M3.

### Automatic unit heater control

The ATC is equipped with an alarm relay with three potential free terminals where M-c is the common terminal. Mnc is normally closed to M-c and Mno is normally potential free. In the event of an alarm Mno closes to M-c and Mnc becomes potential free. The control unit is also equipped with a relay to indicate fan motor operation, for example, to activate tropical fans. This relay has three potential free terminals intended for connecting voltages up to 230VAC where F-c is the common terminal. Fnc is normally closed to F-c and Fno is normally potential free. When the fan motor is activated Fno closes to F-c and Fnc becomes potential free.

An external control signal 0-10 V can be connected to regulate the control system according to the chapter *Control signal range* above.

In order for the equipment to be controlled according to the measured temperature instead of the control signal's value, the function "Activation of 0-10V control signal" must be switched off, see chapter List of parameters. In order for the equipment to be controlled according to the control signals' value instead of the measured room temperature, the function must be switched on. Connection to the temperature control unit is made between terminals X1 and M4.

### Damper motor

A mixing air damper with a 0-10 V input signal can be connected to the control unit. The necessary supply voltage to the damper motor is not provided by the temperature control unit. In order to use the function it is necessary to first fit a freeze protection sensor on the return water pipe, the function must then be activated and finally the required mixing ratio must be defined, where the two latter points are set in the list of parameters. Connection to the temperature control unit is made between terminals Y1 and M5.

### Valve

A motor valve is connected by connecting 230V to terminal Lv1, connecting COM till terminal Nv and the control signal ON/OFF to terminal Lv3. The terminals Y2 and M6 are left unconnected.

### Room thermostat

A temperature sensor must be placed in the room if the control unit shall regulate according to the measured temperature as set out in the chapter *Temperature range* above. Connection to the temperature control unit is made between terminals GT1 and M1.

Table 1 Speed: Speed at respective voltage options, ATDA

	ATDA-30-1-1	ATDA-33-1-1	ATDA-33-1-2	ATDA-44-1-1	ATDA-44-1-2	ATDA-55-1-1	ATDA-55-1-2	ATDA-66-1-1
230 V	1420	1420	1360	1430	1400	935	920	900
150 V	1190	1190	1160	1210	1030	670	420	640
130 V	1035	1035	980	900	750	485	340	505
115 V	850	850	850	660	600	390	280	430
100 V	685	685	680	550	500	310	240	355
80 V	500	500	500	410	380	240	190	270

 =recommended speed

Table 2 Speed: Speed at respective voltage options, LVDV

	LVDV-40-1	LVDV-50
230 V	1300	900
150 V	980	770
130 V	820	690
115 V	690	610
100 V	560	510
80 V	380	370

 =recommended speed

# Installation Package C-box

## Technical data:

**Automatic temperature control unit ATC**  
 IP54, 1 x 230 VAC ±10 %. 2A

**Valve with actuator**  
 IP54, 1 x 230V,  
 Temperature range 2-110°C  
 Kvs 4.0, on/off, time 30 seconds

## Wiring diagram

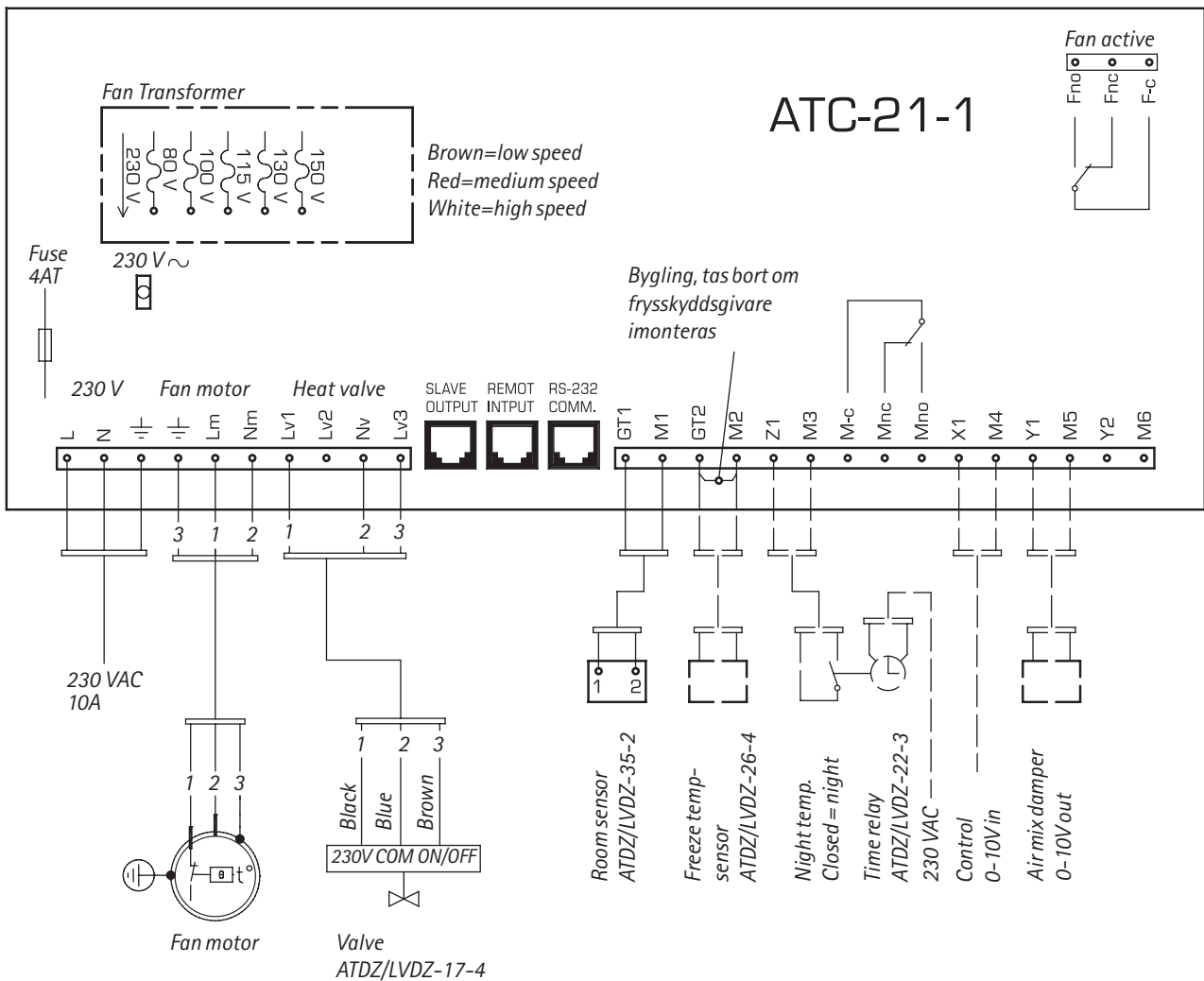



## COILTECH

Coiltech AB, SE-614 81 Söderköping, Sweden  
Phone +46 121 191 00  
Fax +46 121 101 01

Coiltech, Afrikalaan 303, BE-9000 Gent, Belgium  
Phone +32 9 218 71 30  
Fax +32 9 218 71 39

[www.coiltech.com](http://www.coiltech.com)



Head Office:  
IT-33050 POCENIA (UD), Via Giulio Locatelli, 22, Italy  
Phone +39 0432 772 001  
Fax +39 0432 779 594  
[www.ecogroup.com](http://www.ecogroup.com)  
[info@ecogroup.com](mailto:info@ecogroup.com)